

EAN: 8016361938960

MODEL DXOA175AH/1-AUS



FREESTANDING 7.5KG WASHING MACHINE

PRODUCT INFORMATION

Features

- Colour- white (with chrome colour door)
- “One-Touch” feature - can be used andriod phones
- NFC technology (near field communcation)
- Water protection system- foam control, anti overflow
- Spin speed - 1100RPM
- Motor- Inverter
- Stainless steel drum
- Silitech tub
- Door security
- Programmes number 15+1
- Special programs - ALLinONE 20°, all hygiene, ALLinONE 59’, rapid 14’ 30’ or 44’, dark colours, hand wash & silk, wool, rinse, drain & spin, shirts, delicates, mixed, cottons, whites, one touch
- Functions - active steam, rapid/stain level, options, start delay, start/pause, spin speed, temperature selection
- Electronic speed management
- Electronic balance control
- Gross weight 70kg
- Net weight 68kg
- Current A 10
- Fuse rating (A) 10



DYNAMIC NEXT



DISCLAIMER

Eurolinx PTY LTD, is continually seeking ways to improve the design specifications, aesthetics and production techniques of its products. As a result alterations to our products and designs take place continually. Whilst every effort is made to produce information and literature that is up to date, this brochure should not be regarded as an infallible guide to the current specifications, nor does it constitute an offer for the sale of any particular product. Product dimensions indicated in our literature is indicative only. Actual product only should be used to define dimension cut outs. Distributors, and retailers are not agents of Eurolinx and are not authorized to bind Eurolinx by any express or implied undertaking or representation.

FOLLOW US ON: [hover_appliancesAU](https://www.instagram.com/hover_appliancesAU)

www.hooverappliances.com.au

Australian National Telephone Number 1300 694 583
 Office Hours: Monday - Friday 8:30am-5pm
 Showroom Hours: Tuesday - Friday 9am-5pm & Saturday 10am-4pm
 Closed Sunday & Monday

NSW & ACT (Head Office)
 48-50 Moore Street
 Leichhardt
 F 02 8569 4699

VIC & SA
 1211 Toorak Road
 Camberwell
 F 03 9809 2155

QLD
 1/42 Cavendish Road
 Coorparoo
 F 07 3397 0850

WA & NT
 Unit 10/55 Howe Street
 Osborne Park
 F 08 9201 9188

EAN: 8016361938960

MODEL DXOA175AH/1-AUS



FREESTANDING 7.5KG WASHING MACHINE

TECHNICAL DIAGRAM

DXOA 175AH1-AUS

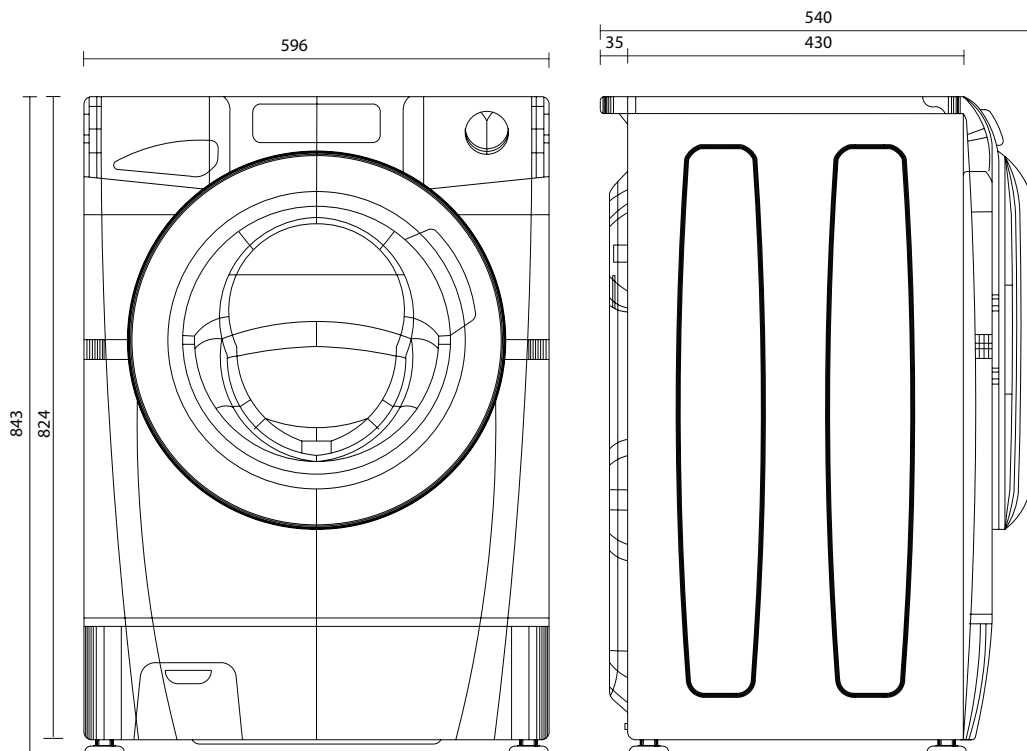

Model DXOA175AH-1 Freestanding 7.5kg washing machine
 Max absorbed power (kW) 1500
 Voltage V 220-240
 Length inlet hose 150cm, length drain hose 200cm, length electrical supply cord 160cm

DISCLAIMER

Eurolinx PTY LTD, is continually seeking ways to improve the design specifications, aesthetics and production techniques of its products. As a result alterations to our products and designs take place continually. Whilst every effort is made to produce information and literature that is up to date, this brochure should not be regarded as an infallible guide to the current specifications, nor does it constitute an offer for the sale of any particular product. Product dimensions indicated in our literature is indicative only. Actual product only should be used to define dimension cut outs. Distributors, and retailers are not agents of Eurolinx and are not authorized to bind Eurolinx by any express or implied undertaking or representation.

10102019

FOLLOW US ON: [hover_appliancesAU](https://www.instagram.com/hover_appliancesAU)

www.hooverappliances.com.au

Australian National Telephone Number 1300 694 583
 Office Hours: Monday - Friday 8:30am-5pm
 Showroom Hours: Tuesday - Friday 9am-5pm & Saturday 10am-4pm
 Closed Sunday & Monday

NSW & ACT (Head Office)
 48-50 Moore Street
 Leichhardt
 F 02 8569 4699

VIC & SA
 1211 Toorak Road
 Camberwell
 F 03 9809 2155

QLD
 1/42 Cavendish Road
 Coorparoo
 F 07 3397 0850

WA & NT
 Unit 10/55 Howe Street
 Osborne Park
 F 08 9201 9188