

ACD60A

# 6kg front-load dryer

WARRANTY  
24  
MONTHS

60CM  
WIDE



**SIZE mm**

600W x 545D x 700H

**FINISH**

white enamel

**CAPACITY**

6kg

**FEATURES**

- PTC heating element (quick dry)
- stainless steel drum
- automatic overheat cutoff
- easy-to-clean double-layer flint filter
- high-speed rotating turbo fan
- automatic disinfection
- child safety lock
- auto stop when door opened
- upright floor mounted
- upside-down wall mounted
- total dry capacity 6kg
- white enamel
- inner drum speed: 50 rpm
- thermostat: 60°C
- centrifugal blast type motor
- mechanical controls
- input power: 800-1400W
- heating power: 700/1300W
- motor output power: 90W
- <6% residual water
- drying time setting: 0-200 minutes
- drum dimensions: 560x304mm
- net weight: 23kg
- 4 x removable 30mmH legs
- spacer
- direct ducting: rear vent for optional fitting of supplied flexible ducting kit
- one-way drum rotation

**POWER**

220-240 V, 50Hz

3-pin 10 amp plug

rated input power: 1500W

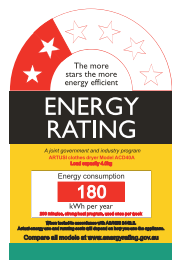

DRYING CAPACITY	DRYING TIME (approx)	
	Regular (minutes)	Airing (minutes)
approx 2kg	30	55
approx 3kg	60	110
approx 4.5kg	200	120
approx 6kg		200

EAN 9347777001252

**DISCLAIMER**

Eurolinx PTY LTD is continually seeking ways to improve the design specifications, aesthetics and production techniques of its products. As a result alterations to our products and designs take place continually. Whilst every effort is made to produce information and literature that is up to date, this brochure should not be regarded as an infallible guide to the current specifications, nor does it constitute an offer for the sale of any particular product. Product dimensions indicated in our literature is indicative only. Actual product only should be used to define dimension cutouts. Distributors, and retailers are not agents of Eurolinx and are not authorized to bind Eurolinx by any express or implied undertaking or representation.

ACD60A

6kg front-load dryer

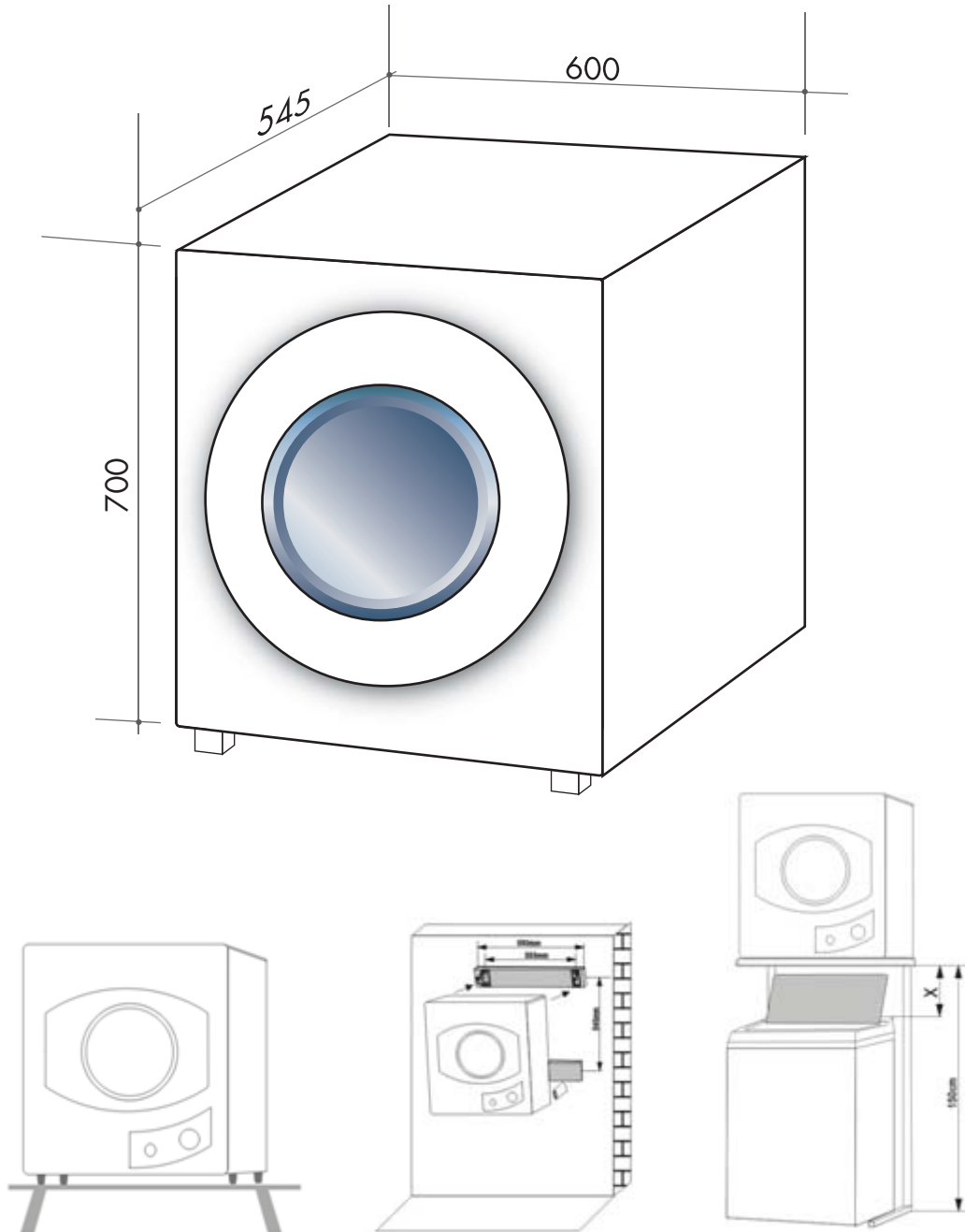

NB: drawings are not to scale — they are to be used . For detailed installation instructions, please refer to user guide.

Australia National Telephone Number 1300 694 583 New Zealand Telephone Number 0508 458 369  
ARTUSI showrooms are open Tuesday to Friday from 9am-5pm and Saturdays 10am-4pm

[artusi.com.au](http://artusi.com.au)

**NSW & ACT**  
(head office)

48 Moore Street  
Leichhardt  
02 8569 4699

**VIC | SA**

1211 Toorak Road  
CAMBERWELL  
03 9809 2155

**TASMANIA**

3 Pear Avenue  
DERWENT PARK 7009  
03 6272 7386

**QLD**

1/42 Cavendish Road  
COORPAROO  
07 3397 0850

**WA | NT**

10/55 Howe Street  
OSBORNE PARK  
08 9201 9188

**New Zealand**

PO Box 11.160  
Sockburn Christchurch  
03 344 5913