

COMMERCIAL PRODUCT

IVUM90 90cm concealed undermount rangehood



SIZE mm	900
FINISH	stainless steel
CAPACITY	850m ³ /hr
FEATURES	<ul style="list-style-type: none"> • 3 speeds • aluminium mesh filter • 41.5 dBA • 150mm ducting outlet • 200W motor output • LED lighting

POWER	10 amps
OPTION	<p>charcoal filter</p> <p>NB: The charcoal filter cleans the circulating air in the room. Such filters cannot be cleaned or recycled and must be replaced at least every four months. The speed at which the charcoal filter becomes saturated depends on how often the fan is used, the type of food that is cooked and how often the grease filter is cleaned.</p>



EAN 9341584031075

DISCLAIMER

Eurolinx Pty Ltd, trading as ILVE Appliances, is continually seeking ways to improve the design specifications, aesthetics and production techniques of its products. As a result alterations to our products and designs take place continually. Whilst every effort is made to produce information and literature that is up to date, this brochure should not be regarded as an infallible guide to the current specifications, nor does it constitute an offer for the sale of any particular product. Product dimensions indicated in our literature is indicative only. Actual product only should be used to define dimension cutouts. Distributors, and retailers are not agents of ILVE Appliances and are not authorized to bind ILVE Appliances by any express or implied undertaking or representation.

COMMERCIAL PRODUCT

IVUM90 90cm concealed undermount rangehood

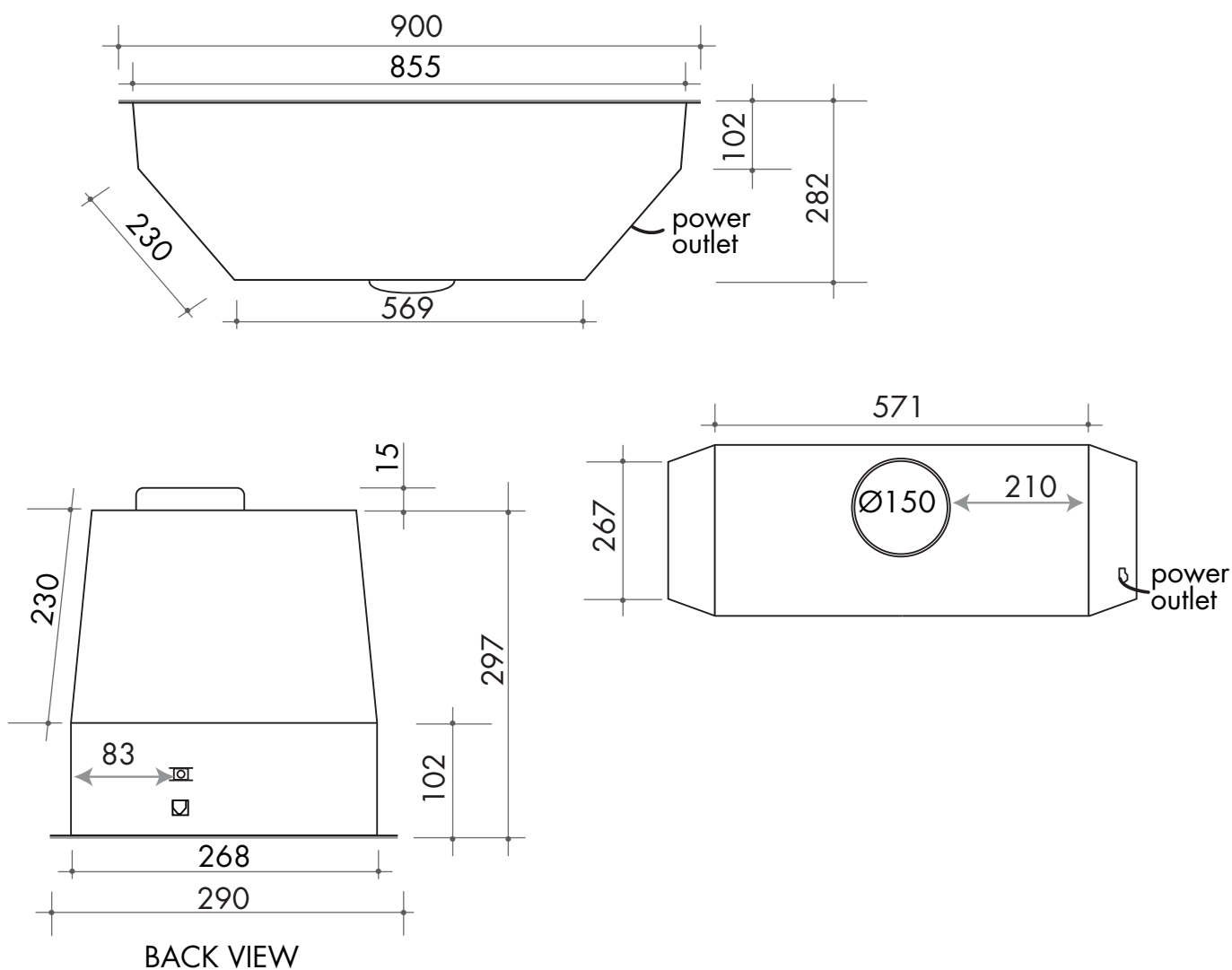

NB: drawings are not to scale — they are to be used as a guide only

You can find us on:



Australia National Telephone Number 1300 MYILVE (694 583) New Zealand Telephone Number 0508 458 369
ILVE showrooms are open daily from 9am-5pm and Saturdays 10am-4pm (WA by appointment only on Saturdays)

ilve.com.au

NSW & ACT (head office)

48 Moore Street
Leichhardt
02 8569 4699

VIC | TAS | SA

1211 Toorak Road
CAMBERWELL
03 9809 2155

QLD

1/42 Cavendish Road
COORPAROO
07 3397 0850

WA | NT

10/55 Howe Street
OSBORNE PARK
08 9201 9188

New Zealand

PO Box 11.160
Sockburn Christchurch
03 344 5906