

COMMERCIAL PRODUCT

IVDFI-1

60cm fully-integrated dishwasher

- SIZE mm** 598W x 550D x 750H + 815min (+50)H
- FINISH** stainless steel interior, door panel supplied and fitted by builder
- CAPACITY** 14 place settings
- FEATURES**
- 6 wash programs — intensive, heavy, normal, 1 hour express, rapid, auto
 - 49 dBA
 - delay start 1–24 hours
 - third layer cutlery basket
 - height-adjustable upper basket
 - Turbo drying system
 - easy-slide cutlery baskets
 - direct injection wash system
 - dual zone alternative wash
 - rinse aid indicator
 - VDE inlet hose with VEE safety certificate can be used with hot water (70–90°C)
 - hot (max 90°C) or cold water connection
- POWER** 10 amp, 3-pin plug



PROGRAM	LOAD	CYCLE	DETERGENT pre/main gr	DURATION minutes	ENERGY kW/hr	WATER litres	RINSE AID
intensive 	for heaviest soiled loads, eg pots, pans, casserole dishes, and dishes that have been sitting with dried food on them for a while	prewash 50°C/prewash wash 65°C rinse/rinse/rinse 55°C drying	5/27.5 (or tablet)	150	1.4	16.5	✓
heavy 	for heavily soiled loads, eg pots, plates, glasses and lightly soiled pans; standard daily cycle	prewash 50°C/wash 55°C rinse/rinse 60°C drying	5/27.5 (or tablet)	180	1.15	13	✓
normal* 	for normally soiled loads, eg plates, glasses, bowls and normally soiled pans	prewash/wash 45°C rinse/rinse 50°C drying	5/27.5 (or tablet)	165	0.71	13	✓
glass 	for lightly soiled crockery and glass	prewash/wash 40°C rinse/rinse 50°C drying	5/27.5	120	0.85	13	✓
1 hour 1 Hour 	for lightly soiled loads that do not need drying	prewash 50°C/wash 60°C rinse 50°C drying	5/27.5	60	0.8	9	✓
rapid 	a shorter wash for lightly soiled loads that do not need drying	wash 40°C rinse/rinse 45°C	20	40	0.5	10	

* AS/NZS 2007.1: Test cycle program | ✓ Rinse Aid required

NB: We recommend opening door 50mm at end of wash to assist drying

EAN 9341584028150

DISCLAIMER

EuroInx Pty Ltd, trading as ILVE Appliances, is continually seeking ways to improve the design specifications, aesthetics and production techniques of its products. As a result alterations to our products and designs take place continually. Whilst every effort is made to produce information and literature that is up to date, this brochure should not be regarded as an infallible guide to the current specifications, nor does it constitute an offer for the sale of any particular product. Product dimensions indicated in our literature is indicative only. Actual product only should be used to define dimension cutouts. Distributors, and retailers are not agents of ILVE Appliances and are not authorized to bind ILVE Appliances by any express or implied undertaking or representation.

IL300616

COMMERCIAL PRODUCT

IVDFI-1

60cm fully-integrated dishwasher

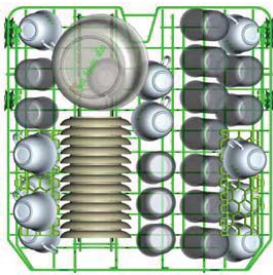

The upper basket is designed to hold more delicate and lighter dishware such as glasses, coffee and tea cups and saucers, as well as small plates and bowls and shallow pans (provided they are not too soiled).

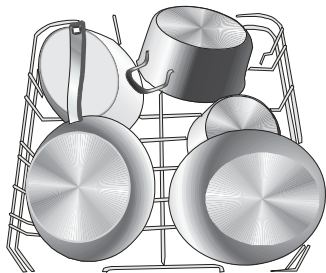

It is suggested that large items, and items that are most difficult to clean, are placed in the lower basket — eg pots, pans, lids, serving dishes etc. It is preferable to place serving dishes and lids on the side of the racks to avoid blocking rotation of the top spray arm.

NB: drawings are not to scale — they are to be used as a guide only. For detailed installation instructions, please refer to user guide.

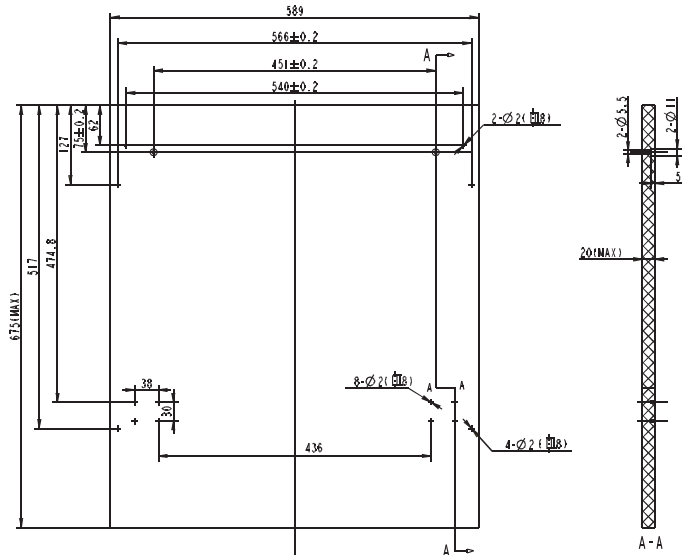
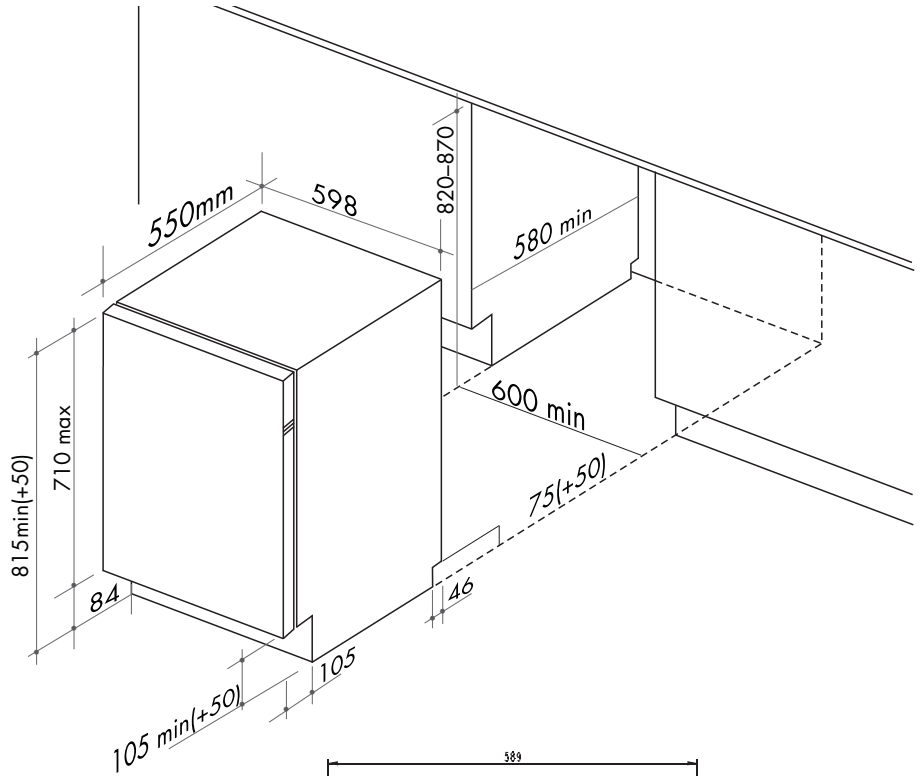

You can find us on:



Australia National Telephone Number 1300 MYILVE (694 583) New Zealand Telephone Number 0508 458 369
ILVE showrooms are open daily from 9am-5pm and Saturdays 10am-4pm (WA by appointment only on Saturdays)

ilve.com.au

NSW & ACT
(head office)

48 Moore Street
Leichhardt
02 8569 4699

VIC | SA

1211 Toorak Road
CAMBERWELL
03 9809 2155

TASMANIA

3 Pear Avenue
DERWENT PARK 7009
03 6272 7386

QLD

1/42 Cavendish Road
COORPAROO
07 3397 0850

WA | NT

10/55 Howe Street
OSBORNE PARK
08 9201 9188

New Zealand

PO Box 11.160
Sockburn Christchurch
03 344 5906