

COMMERCIAL PRODUCT

IVC48

90cm canopy rangehood



SIZE mm	900
FINISH	AS430 stainless steel
CAPACITY	1000m ³ /hr
FEATURES	<ul style="list-style-type: none"> • brushed stainless steel • 1000m³/hr • single motor • 4 speeds • electronic push-button controls • 2 x 20W halogen globes • 150mm ducting • 10 amps, 3-pin plug and cord
POWER	supplied with 150mm power cord 10 amps



Rangehood extraction rate m³/hr reading is measured at 1m duct up, 1x90° C bend and 1m vertical duct



EAN 9341584035707

DISCLAIMER

Eurolinx Pty Ltd, trading as ILVE Appliances, is continually seeking ways to improve the design specifications, aesthetics and production techniques of its products. As a result alterations to our products and designs take place continually. Whilst every effort is made to produce information and literature that is up to date, this brochure should not be regarded as an infallible guide to the current specifications, nor does it constitute an offer for the sale of any particular product. Product dimensions indicated in our literature is indicative only. Actual product only should be used to define dimension cutouts. Distributors, and retailers are not agents of ILVE Appliances and are not authorized to bind ILVE Appliances by any express or implied undertaking or representation.

COMMERCIAL PRODUCT

IVC48

90cm canopy rangehood

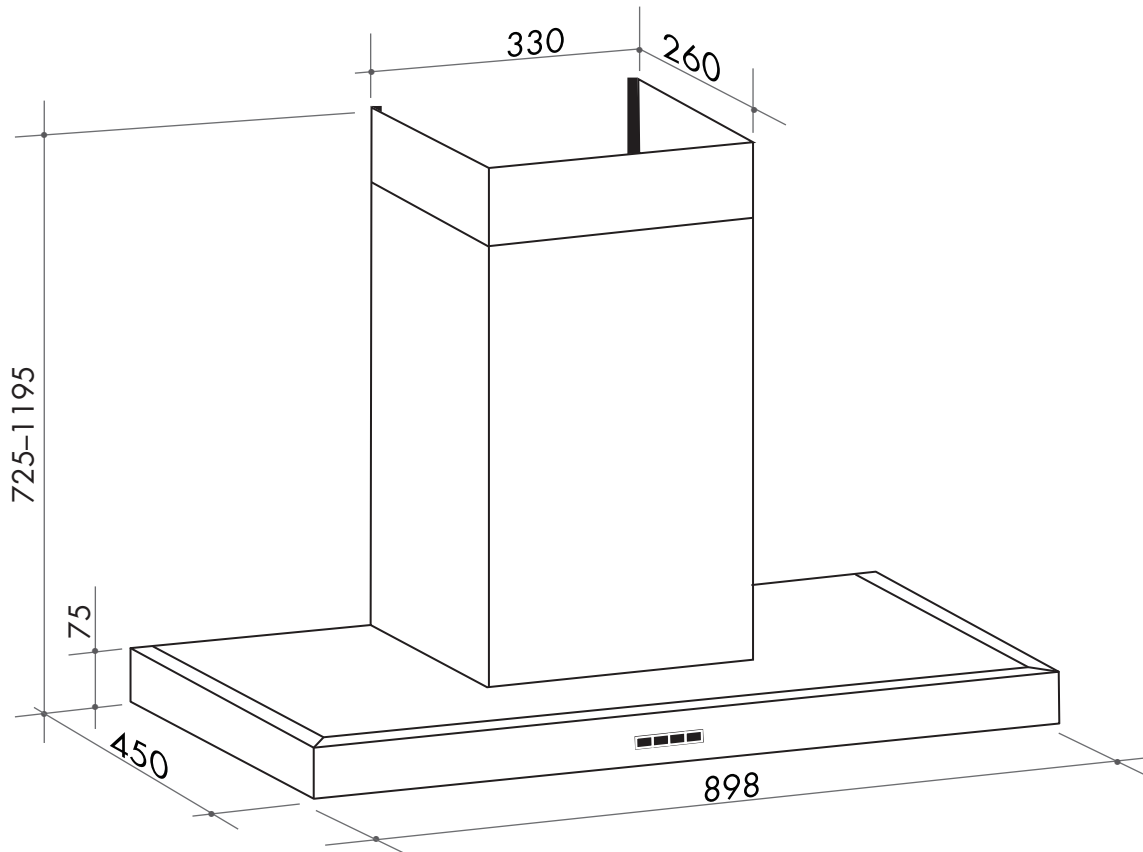

NB: drawings are not to scale — they are to be used as a guide only.
For detailed installation instructions, please refer to user guide.

You can find us on:

 facebook.com/ILVEappliances

 twitter.com/ILVE_appliances

 youtube.com/ILVEappliances

 livewithilve.com

Australia National Telephone Number 1300 MYILVE (694 583) New Zealand Telephone Number 0508 458 369

ILVE showrooms are open Tuesday to Friday from 9am-5pm and Saturdays 10am-4pm (WA by appointment only on Saturdays)

ilve.com.au

NSW & ACT
(head office)

48 Moore Street
Leichhardt
02 8569 4699

VIC | SA

1211 Toorak Road
CAMBERWELL
03 9809 2155

TASMANIA

3 Pear Avenue
DERWENT PARK 7009
03 6272 7386

QLD

1/42 Cavendish Road
COORPAROO
07 3397 0850

WA | NT

10/55 Howe Street
OSBORNE PARK
08 9201 9188

New Zealand

PO Box 11.160
Sockburn Christchurch
03 344 5906